



# 4JH5E Series

Configuration	4-stroke, vertical, water-cooled diesel engine		
Maximum output at crankshaft	* 39.6 kW@3000 rpm	[53.1 mhp@3000 rpm]	
Displacement	2.19 ltr	[134 cu in]	
Bore x stroke	88 mm x 90 mm	[3.46 in x 3.54 in]	
Cylinders	4 in line		
Combustion system	Direct injection		
Aspiration	Natural aspiration		
Starting system	Electric starting 12V - 1.4 kW		
Alternator	12V - 125A		
Cooling system	Fresh water cooling by centrifugal water pump and rubber impeller sea water pump		
Lubrication system	Enclosed, forced lubricating system		
Direction of rotation [crankshaft]	Counterclockwise viewed from flywheel side		
Dry weight without gear	201 kg	[443 lbs]	
Environmental	EU: RCD	BSO II	EMC
Engine mounting	Rubber type flexible mounts		

**NOTE:**

Fuel condition: Density at 15°C = 0.84 g/cm<sup>3</sup>: 1 kW = 1.3596 mhp = 1.3410 HP  
 \* Fuel temperature 40°C at the inlet of the fuel injection pump [ISO 8665: 2006]  
 Technical data is according to ISO 8665: 2006/3046-1

**DIMENSIONS**

**Rear view**

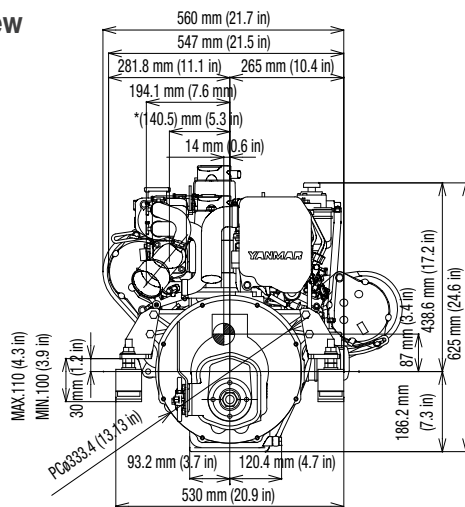

**Right side view**

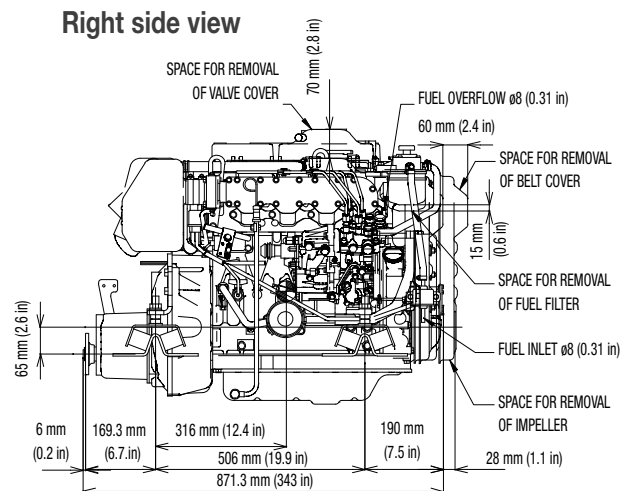

4JH5E with KM35P marine gear



PERFORMANCE CURVES

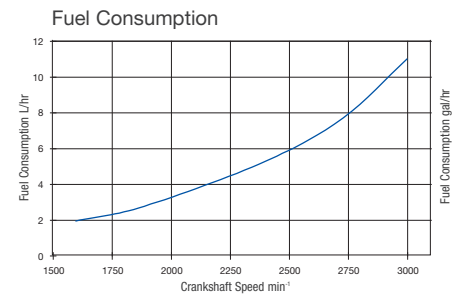
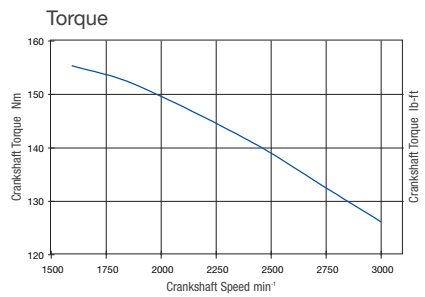
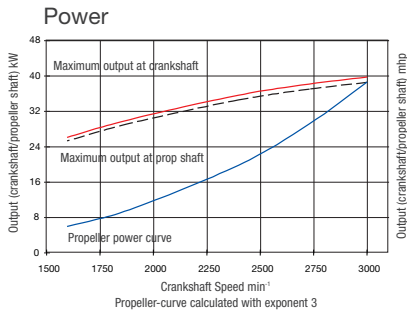

MARINE GEARS/DRIVE

Model	KM35P		KM35A2 [down angle: 7°]		KM4A1 [down angle: 7°]			ZF30M		Saildrive SD60	
Type	Mechanical cone clutch		Mechanical cone clutch		Mechanical cone clutch			Mechanical multi-disc		Mechanical wet type multi-disc	
Dry Weight	12 kg [27 lbs]		13 kg [29 lbs]		29 kg [64 lbs]			28 kg [61 lbs]		40 kg [88 lbs]	
Reduction Ratio [fwd/asn]	2.36/3.16    2.61/3.16		2.33/3.06    2.64/3.06		1.47/1.47    2.14 / 2.14    2.63/2.63			2.15/2.64    2.70/2.64		2.23/2.23    2.49/2.49	
Propeller speed [fwd/asn]	1271/949    1149/949		1288/980    1136/980		2041/2041    1402/1402    1141/1141			1395/1136    1111/1136		1345/1345    1205/1205	
Direction of rotation [propeller shaft - fwd]	Clockwise viewed from stern		Clockwise viewed from stern		Clockwise viewed from stern			Clockwise viewed from stern		Clockwise & counterclockwise viewed from stern	
Dry weight - engine & gear	213 kg [469.5 lbs]		214 kg [471.7 lbs]		214 kg [471.7 lbs]			229 kg [505 lbs]		241 kg [531 lbs]	
Length engine and gear/drive	871 mm [34 in]		864 mm [34 in]		922 mm [36 in]			950 mm [37 in]		1113 mm [44 in]	

INSTRUMENT PANELS

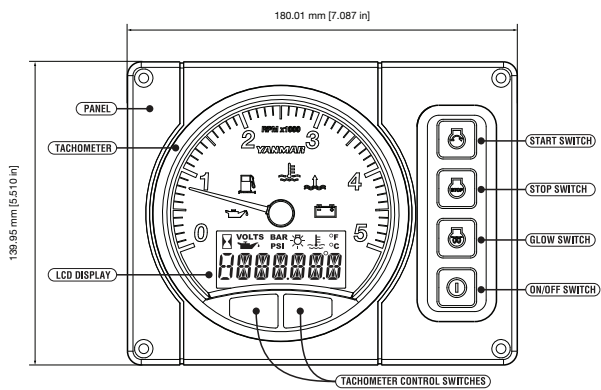

B20 STANDARD

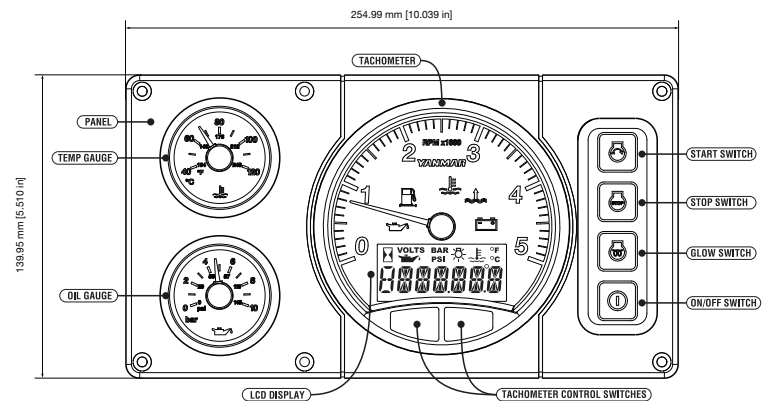

C30 OPTIONAL

ACCESSORIES

**Standard Package**

- Set of flexible engine mounts
- Exhaust mixing elbow [L-type]
- V-belt safety cover
- Fresh water expansion tank
- Alternator 12V - 125A
- Electric stop solenoid
- Operation manual
- B20-panel
- Sensor for instrument panel

**Optional**

- Second alternator 12V - 130A or 24V - 75A, including smart regulator
- High-riser mixing elbow [instead of L-elbow]
- Extension wire harness [4m, 6m, 10m]
- Hot water kit with cocks
- Second station harness
- C30-panel
- Sensor for C30-panel
- Extension saildrive leg [75 mm]
- Propeller cone nut kit SD60

NOTE: All data subject to change without notice. Text and illustrations are not binding.